

# Heatless Air Dryers



TW Series

# Heatless Air Dryer Operation

Airtek Heatless Dryers remove water vapor from compressed air through a process known as Pressure Swing Adsorption. Pressure dew points ranging from -40°F to -100°F are attained by directing the flow of saturated compressed air over a bed of desiccant. The most commonly used desiccant is activated alumina, a spherical shaped, hygroscopic material, selected for its consistent size, shape and extreme surface to mass ratio. This physically tough and chemically inert material is contained in two separate but identical pressure vessels commonly referred to as "dual" or "twin" towers. As the saturated compressed air flows up through the "on line" tower, its moisture content adheres to the surface of the desiccant. The dry compressed air is then discharged from the chamber into the distribution system.

A solid state controller automatically cycles the flow of compressed air between the towers, while the "on line" tower is drying, the "off line" tower is regenerating. Regeneration, sometimes referred to as purging, is the process by which moisture accumulated during the "on line" cycle is stripped away during the "off line" cycle. As low pressure dry purge air flows gently through the regenerating bed, it attracts the moisture that had accumulated on the surface of the desiccant during the drying cycle and exhausts it to the atmosphere.

To protect the desiccant bed from excess liquid, all Airtek heatless dryers are designed to work with the natural pull of gravity. By directing the saturated air into the bottom of the "on line" tower and flowing up through the bed, liquid condensate caused by system upset, is kept away from the desiccant and remains at the bottom of the tower where it can be easily exhausted during the regeneration cycle.

Counter flow purging ensures optimum performance by keeping the driest desiccant at the discharge end of the dryer.

Moisture load, velocity, cycle time and contact time determine tower size and the amount of desiccant. To ensure design dew point, each tower is carefully sized to allow a minimum of 5.5 seconds of contact. To prevent desiccant dusting and bed fluidization, air flow velocities are kept below 50 feet per minute. The dryer can cycle for years without changing the desiccant.

Heatless dryers in general are the most reliable and least expensive of all desiccant type dryers. Airtek Heatless Dryers are the most energy efficient thanks to standard features like, "Variable Cycle Control", "CycleLoc", and "ProPurge".

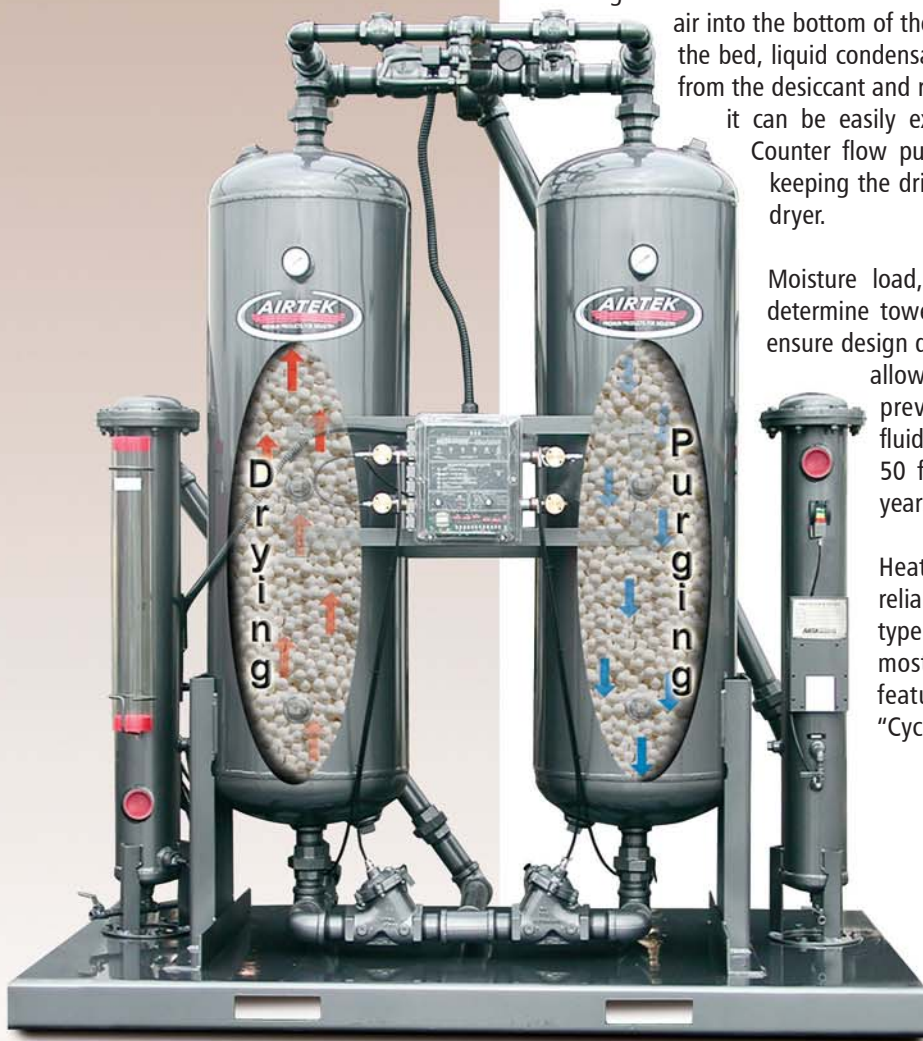

TW600 with package "E"  
(Cutaway showing air flow)

# Valves

## Non-Lubricated Valves

Dryers 75 to 800 SCFM are equipped with our time-proven and dependable non-lubricated switching valves. The independent, air operated valves are specifically designed for compressed air service. They are resistant to desiccant dust and can be maintained without being removed from the dryer.



## Rotary Actuated Valves

High performance, Rotary Actuated Switching Valves are standard on dryers 1,000 SCFM and larger. These premium, air operated butterfly valves are specifically designed to allow higher flow with lower associated pressure drop. They provide more opening and closing force compared to other types of valves. An indicator shows the "open/closed" position of the valve and service can be performed without disturbing dryer piping.

These valves are so reliable, they carry a three-year factory warranty.

## Purge Flow Regulator

While other dryers use a manual valve for purge control, Airtek provides a Purge Flow Regulator. Due to system pressure fluctuation, dryers equipped with manual purge valves waste air and energy by over-purging when system pressure is high and sacrifice performance by under-purging when system pressure is low. Manual purge valves do not compensate for system pressure variance. Airtek's exclusive Purge Flow Regulator saves energy and ensures performance by maintaining optimum purge regardless of system pressure. To prevent the purge flow from fluctuating and to discourage unauthorized tampering, the Purge Flow Regulator can be locked into position.



# Master Control

## Sequence Annunciator

Airtek's Sequence Annunciator is a solid state visual display panel that shows exactly what is happening in the dryer. The panel lights signal which tower is "on line" drying, and whether the "off line" tower is purging, repressurizing or in "CycleLoc". It will also annunciate optional equipment operation and function alarms. The panel is integral with the NEMA 4 Master Control and is conveniently mounted for easy monitoring.

## CycleLoc

Significant energy savings and reduced air compressor demand are achieved by cycling the dryer with the air compressor. When the air compressor unloads or shuts off, "CycleLoc" automatically stops the purge and holds the dryer's cycle position until load is resumed. The "CycleLoc" function is activated by the air compressor's relay or pressure switch. Contacts are provided in the dryer's NEMA 4 control panel. A panel mounted light indicates "CycleLoc" activation.

## Variable Cycle Control

Additional energy savings can be achieved by adjusting the amount of purge to the actual moisture load. When demand is expected to be less than maximum, Airtek's Variable Cycle Control provides a means to adjust the purge cycle time to reduce the total amount of purge used for regeneration. As a result of less frequent cycling, the desiccant will last longer and the switching valves will require less maintenance. The Variable Cycle Control incorporates a short cycle position that can be employed to provide dew points as low as -80°F.

## Surge Protection

To accommodate the unique requirements of centrifugal compressors, all Airtek desiccant dryers are now programmed with a special anti-surge control. A sequenced timing circuit eliminates potential compressor surge by preventing momentary flow restrictions from occurring at tower switch over.

Total dryer operation is managed by Airtek's NEMA 4 automatic control center. The solid state module controls all dryer functions including the Sequence Annunciator.

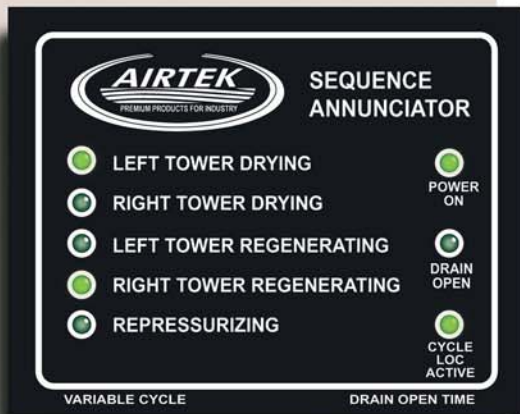

Models TW10-TW55

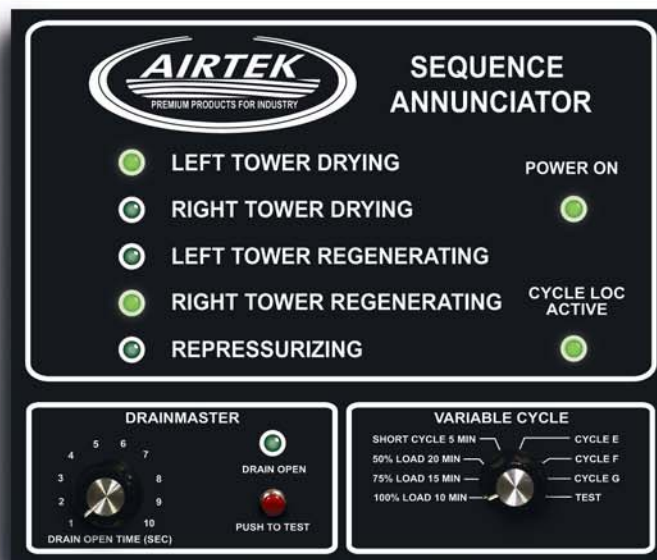

Models TW75-TW200

# Pro-Purge Demand Control

## Pro-Purge Operation

Airtek's Pro-Purge is standard equipment on Heatless Air Dryers 250 scfm and larger. It is an advanced "Proportional Demand Controller" that saves energy by automatically regulating the purge cycle in response to actual loads. Moisture loads fluctuate throughout the day and rarely reach maximum moisture levels, and therefore, waste energy by regenerating more often than is necessary. The Pro-Purge monitors actual compressed air moisture levels and prevents cycle advancement until the designed saturation is read.

## LED Display Panel

The Pro-Purge Panel lights indicate:

- Power Saver Mode/Demand Control active "ON" LED.
- "OFF" LED indicates the Pro-Purge Demand Control is deactivated and the dryer is functioning in the fixed cycle default mode.

## High Dew Point Alarm

The High Dew Point Alarm is activated when dew points rise above -20°F. It would also activate in the event of a short circuit or should the sensor become disconnected. Dry contacts for an external alarm are provided.

## Retrofit Capability

The Pro-Purge module can be retrofitted to all older Airtek Heatless Air Dryers

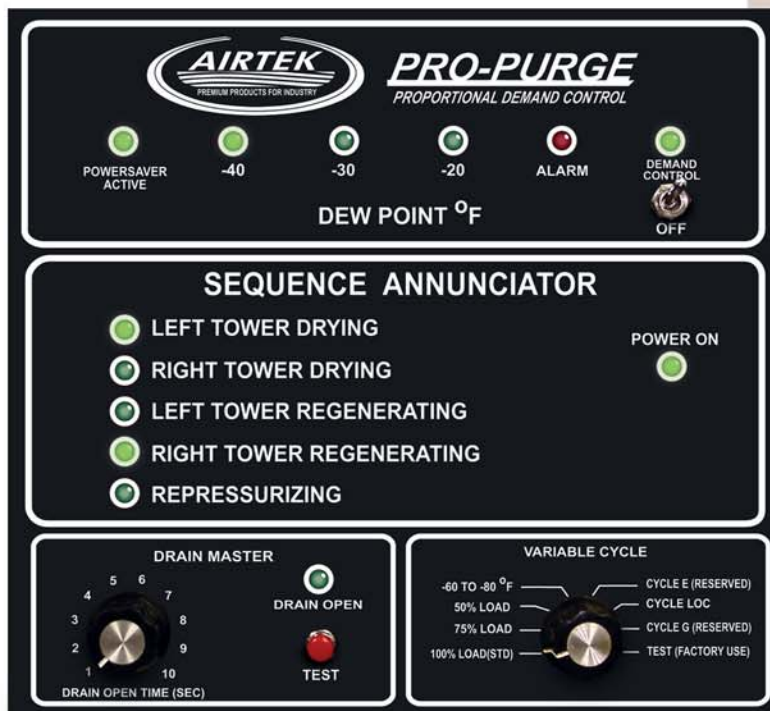

Models TW250-TW6000



# Package "E" Complete Air Treatment

Without proper filtration, desiccant air dryers will not work. Desiccant dryers are designed to adsorb vapor from compressed air; they are not designed for liquid. When liquid, especially oil, is allowed to enter the desiccant chamber, it coats the desiccant material preventing any further adsorption. Oil coated desiccant can not be regenerated, and must be replaced. To protect the desiccant from contact with liquids, a coalescing pre-filter is required. The pre-filter must be properly sized and properly installed with a dependable automatic drain and a visual indicator to determine element condition. To protect downstream equipment from potential damage caused by the abrasive effects of desiccant dust, a particulate after-filter is also required.

Most field problems experienced with desiccant air dryers are the result of improper filter selection, installation, maintenance, and/or draining of condensate.

Considering the importance of filtration to dryer performance, Airtek recommends that all desiccant dryers be ordered as a complete, factory assembled Air Treatment System. The Optional Airtek Package "E" includes: properly sized, factory installed coalescing pre-filter and particulate after filter with electronic drain system (No Loss Demand Drains standard on 400 SCFM and larger), and visual element condition indicators.

Factory packaging, with matched components and single point connections reduces installation costs, ensures performance and allows Airtek to assume total responsibility for system integrity.



Model TW1000 with Package "E" with PowerLoc

# Package Schematics

## Package "E"

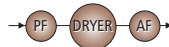

Includes dryer with factory installed pre-filter and after-filter.

## Package "EB"

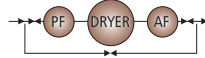

Includes dryer with factory installed pre-filter and after-filter with system bypass.

## Package "EC"

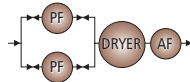

Includes dryer with factory installed dual selectable pre-filters and single after-filter.

## Package "ED"

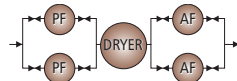

Includes dryer with factory installed dual selectable pre and after-filters.

Note: Consult factory for other package configurations

## Filters

Airtek Package "E" systems match our TW Heatless dryers with Airtek high performance filters. In-line filters (JW) are used on systems 100 through 300 SCFM and two stage (JL) severe duty filters are used on systems 400 SCFM and larger.

The coalescing pre-filter is installed at the dryer inlet. It protects the dryer by removing liquids and reducing the contamination level of the compressed air to .01 PPM by weight. The element is DOP rated at 99.9+% efficient in the 0.3 to 0.6 micron range. An integrated digital indicator is provided to determine element condition. An electronic drain valve is provided on systems 100 through 300 SCFM to ensure proper drainage. On systems 400 SCFM and larger a zero air loss demand drain is provided. The drain controller includes push to test, drain alarm, and common alarm contact.

To protect downstream equipment from desiccant dust a particulate after-filter is installed at the dryer discharge. The after-filter element is designed to remove solid particulates from compressed air. The hybrid pleated filter media provides high dirt retention, low pressure drop, and long element life. The element is 100% effective in removing particles 0.9 micron and larger. A integrated digital element condition indicator is also provided.

Note: Optional Mist Eliminators are available as extra protection for standard packages.

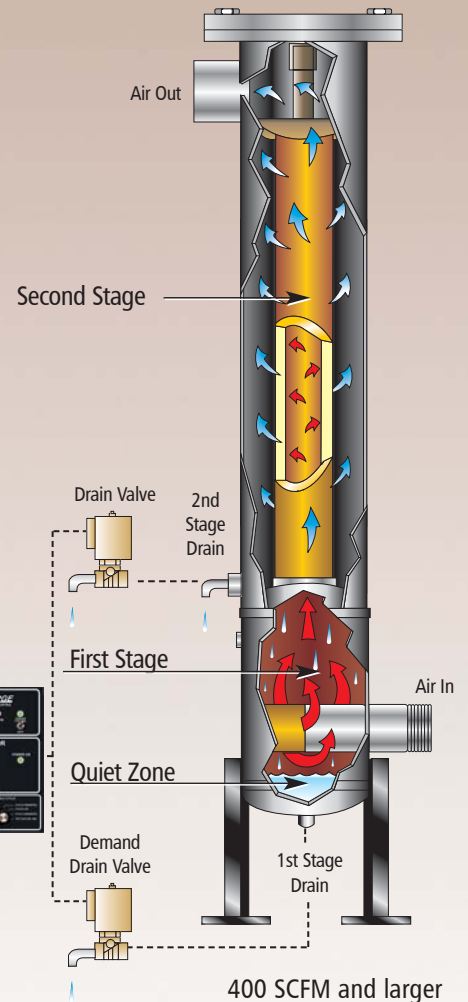

# PowerLoc Energy Management System

## Energy Savings and Operating Cost Reduction

PowerLoc automatically adjusts energy use to actual moisture load. Moisture loading is affected by inlet temperature, pressure, relative humidity and flow. These conditions vary throughout the day and rarely combine in such a manner as to produce maximum moisture loads. An inlet temperature reduction of just 20°F (-7°C) will reduce the moisture load by almost 50%. Desiccant dryers are normally sized for “worst case” operation with the cycle fixed to accommodate maximum moisture loads. Because the fixed cycle does not compensate for fluctuating loads, dryers not equipped with PowerLoc or Pro-Purge waste energy by regenerating more often than necessary. PowerLoc eliminates the unnecessary use of energy by delaying regeneration until the total design moisture load is achieved. The system monitors actual moisture loading and limits the number of purge cycles accordingly.

At \$0.08 per Kwh, the PowerLoc would save over \$10,000 annually when used with a 1,000 SCFM heatless dryer operating at 70% load for 8,000 hours at an average inlet temperature of +85°F (29°C). Digital dew point control provides for additional energy savings by allowing the operator to select higher dew points when appropriate. The moisture probe is contained in and protected by a rugged, stainless steel housing that also contains an electronics package for continuous self calibration, temperature compensation, and signal stabilization. Due to less frequent cycling, switching valves and desiccant will last longer and require less maintenance.

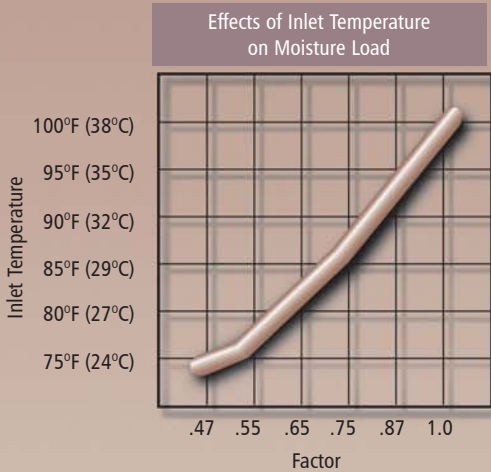

The PowerLoc ceramic sensor is made from state-of-the-art metalized ceramic and replaces traditional materials such as aluminum, silicon and hygroscopic salts. This fast response sensor is made from a ceramic tile that is plated and vapor deposited to form a surface that is very sensitive to small changes in water vapor pressure.

The proprietary coating processes make the ceramic sensor inherently faster to respond than other impedance or capacity sensors currently available. The ceramic sensor features the latest digital technology with calibration data stored directly in the sensor's memory, and is equipped with a built-in thermistor for automatic temperature compensation. The PowerLoc is traceable to the National Institute of Standards and Technology. A certificate of traceability is available.

The PowerLoc ceramic sensor is protected by an 80 micron sintered metal guard and is enclosed in a rugged, stainless steel housing with a pressure rating of 5,000 PSIG. This housing increases the sensor's ability to withstand reasonable shock and vibration.



# Typical Compressed Air System

Compressed Air Source →

## Coalescer - Standard C6

**General Plant Air:** High efficiency coalescing applications when removal of liquid and suspended fines are required.

**Air Dryer System:** Pre-filter protection for desiccant type air dryers. Maintains dryer efficiency by preventing coating of bed with oil or varnish. Removes condensed water, leaving only vapors for dryer to remove. Prevents catastrophic oil flood should separator fail.

## Coalescer - C8

**General Plant Air:** Good air coalescing efficiency in combination with high flow rate and long element life. Generally used for plant air source system. Separate pre-filter not required for "normal to light" particulate loading.

**Air Dryer System:** Pre-filter protection for refrigerated type air dryers. Maintains dryer efficiency by preventing coating of coils with oil or varnish. Removes condensed water, leaving only vapors for dryer to remove. Prevents catastrophic oil flood should separator fail.

## Coalescer - C10

**General Plant Air:** Pre-coalescer for heavy liquid aerosol loads. Pre-filter for grades 6 and 8 when varnishing occurs due to high temperature operation with hydrocarbon oil.

**Air Dryer System:** Provides after-filter safety in high temperature configuration.

## Particulate - F

**General Plant Air:** Prefilter for coalescers where solid particle contaminates show heavy presence. Source particulate filtration where very high dirt loading capacity is required.

**Air Dryer System:** Safety after- filter for desiccant type dryers to control dusting to the 3um absolute level.

## Adsorber - A

**General Plant Air:** Polishing gas stream of final trace hydrocarbon contaminant's when inlet concentrations are between .5 to 2.0 ppm. Neutralizes odor/taste of compressed air for edible products and other source applications where trace hydrocarbon vapor removal is required.

Note: Airtek JL Series Filters do not require particulate pre-filtration as they incorporate a multi-stage design that satisfies the pre-filter requirements stated above.

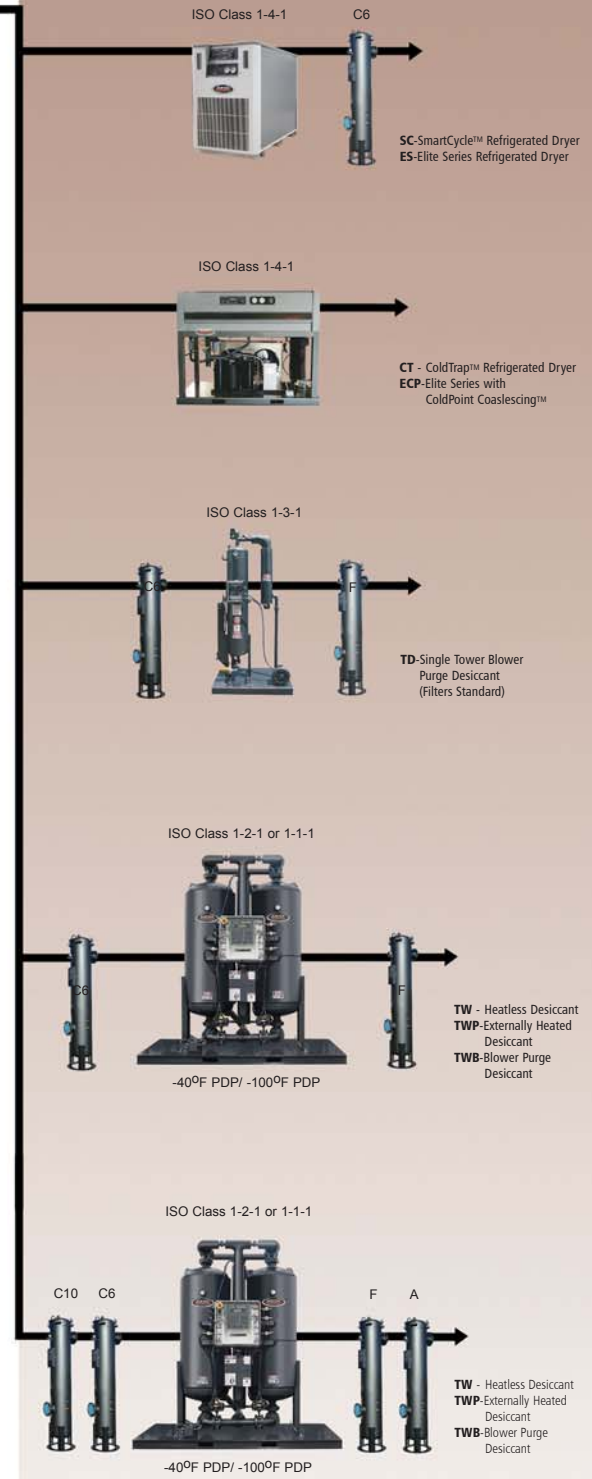

## ISO Classification

ISO 8573.1 Quality Class	Solid		Water		Oil	
	Maximum Particle Size (µm)	Max. Concentration ppm (mg/m <sup>3</sup> )	Max. Pressure Dewpoint °F (°C)		Max. Concentration ppm (mg/m <sup>3</sup> )	
1	0.1	.08 (0.1)	-94	(-70)	.008	(0.01)
2	1	.8 (1)	-40	(-40)	.08	(0.1)
3	5	4.2 (5)	-4	(-20)	.83	(1)
4	15	6.7 (8)	37	(+3)	4.2	(5)
5	40	8.3 (10)	45	(+7)	21	(25)
6	-	-	50	(+10)	-	-

# Engineering Data Specifications

TW Heatless Air Dryer				Dryer with Package "E"					Air In/Out
MODEL	Capacity SCFM @ 100 PSIG (Nm <sup>3</sup> /min@6.9 Bar)	Approximate Purge SCFM (Nm <sup>3</sup> /min)	Recommended Package "E"	A Length (mm)	B Width (mm)	C Height (mm)	Weight Lbs (Kg)		
TW10**	10 (.28)	2 (.05)	TA-PE0020	19" (483)	16" (406)	46" (1168)	108 (49)	3/8"	
TW15**	15 (.42)	2 (.05)	TA-PE0020	19" (483)	16" (406)	46" (1168)	112 (51)	3/8"	
TW25**	25 (.70)	4 (.11)	TA-PE0050	19" (483)	16" (406)	64" (1626)	156 (71)	1/2"	
TW40**	42 (1.19)	6 (.19)	TA-PE0050	21" (533)	17" (432)	48" (1219)	190 (86)	1/2"	
TW55**	60 (1.70)	9 (.25)	TA-PE0085	21" (533)	20" (508)	67" (1702)	230 (104)	3/4"	
TW75	75 (2.13)	11 (.31)	TA-PE0085	35" (889)	27" (686)	80" (2032)	384 (174)	3/4"	
TW100	107 (3.03)	16 (.45)	TA-PE0110	35" (889)	27" (686)	80" (2032)	468 (212)	1"	
TW130	135 (3.82)	20 (.56)	TA-PE0150	35" (889)	21" (533)	70" (1778)	496 (225)	1"	
TW200	200 (5.66)	30 (.84)	TA-PE0200	44" (1118)	28" (711)	78" (1981)	692 (314)	1 1/2"	
TW250	250 (7.07)	38 (1.07)	TA-PE0300	44" (1118)	30" (762)	78" (1981)	776 (352)	1 1/2"	
TW300	300 (8.49)	45 (1.27)	TA-PE0300	44" (1118)	30" (762)	78" (1981)	796 (361)	1 1/2"	
TW400	400 (11.32)	60 (1.69)	TA-PE0400	74" (1880)	41" (1041)	84" (2134)	1626 (738)	2"	
TW500	510 (14.44)	77 (2.18)	TA-PE0600	74" (1880)	41" (1041)	85" (2159)	1735 (787)	2"	
TW600	650 (18.40)	98 (2.77)	TA-PE0600	74" (1880)	41" (1041)	86" (2184)	1740 (789)	2"	
TW770	800 (22.65)	120 (3.39)	TA-PE0800	74" (1880)	41" (1041)	91" (2311)	2120 (962)	2"	
TW1000	1000 (28.31)	150 (4.24)	TA-PE1000	108" (2743)	54" (1372)	88" (2235)	3676 (1667)	3" FL	
TW1200	1200 (33.98)	180 (5.09)	TA-PE1250	108" (2743)	54" (1372)	111" (2819)	4605 (2089)	3" FL	
TW1500	1500 (42.47)	225 (6.37)	TA-PE1600	114" (2896)	66" (1676)	100" (2540)	4985 (2261)	4" FL	
TW2000	2000 (56.63)	300 (8.49)	TA-PE2000	120" (3048)	66" (1676)	100" (2540)	5206 (2361)	4" FL	
TW2600	2600 (73.62)	390 (11.04)	TA-PE2600	144" (3658)	72" (1829)	110" (2794)	7600 (3447)	4" FL	
TW3000	3000 (84.95)	450 (12.74)	TA-PE3000	144" (3658)	72" (1829)	110" (2794)	8300 (3765)	4" / 6" FL	
TW4000	4000 (113.26)	600 (16.99)	TA-PE4000	204" (5182)	84" (2134)	112" (2845)	10300 (4672)	6" FL	
TW5000	5000 (141.58)	750 (21.23)	TA-PE6000	156" (3962)	84" (2134)	115" (2921)	12700 (5761)	6" FL	
TW6000	6000 (169.50)	900 (25.48)	TA-PE6000	192" (4877)	84" (2134)	114" (2896)	16500 (7484)	6" FL	

Notes: \*\* Electronic Switching Valves

- Dimensions and weight are for dryer with Package "E" installed.
  - Dimensions measured in inches and millimeters.
  - Weight measured in pounds and kilograms and includes desiccant (shipped loose models 1500 and up).
  - Specifications and dimensions are subject to change without notice.
- Pressure Drop at Rated Flow: Less Than 5 PSI (0.34 Bar)
  - Maximum Inlet Air or Ambient Air Temperature 120°F (49°C)
  - Maximum Working Pressure: 150 PSIG (10.5) Standard  
Units for higher maximum working pressures are available, see TX models
  - Minimum Operating Pressure: 50 PSIG (3.5 Bar)

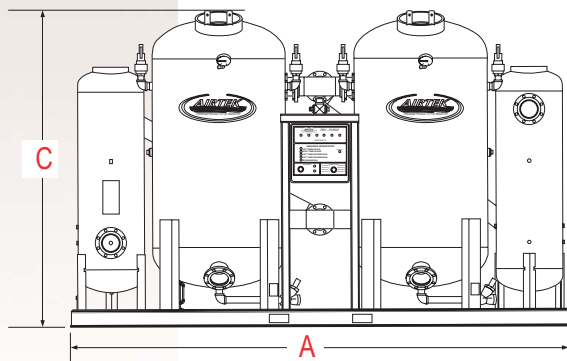

Front View: TW6000

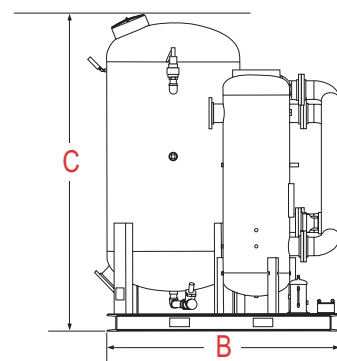

Side View: TW6000

# Available Equipment

## Standard Equipment

- Electric 120/1/60
- Pro Purge Demand Controller (250-6,000 scfm)
- Solid State Controller
- Centrifugal Compressor Surge Protection (75-6,000 scfm)
- System Sequence Annunciator
- CycleLoc Demand Control
- Variable Cycle Control (75-6,000 scfm)
- Purge Flow Indicator
- Purge Flow Regulator (75-3,000 scfm)
- Repressurization Circuit (75-6,000 scfm)
- Control Air Filter (75-6,000 scfm)
- High Performance Butterfly Valves (1,000-6,000 scfm)

- 3-Year Valve Warranty (1,000-6,000 scfm)
- ASME Coded Pressure vessels (100-6,000 scfm)
- Separate Tower Pressure Gauges
- Safety Valves
- Cushioned Seat, Check Valves
- Separate Fill /Drain Ports
- NEMA 4 Controls
- Stainless Steel Diffuser Screen
- Pressure Equalization
- Structural Steel Base
- 150 PSIG Design Standard
- Moisture Indicator (75-200 scfm)

## Optional Equipment

- Filter Packaging with  $\Delta P$  Gauges
- Pro-Purge Demand Control (10-200 scfm)
- PowerLoc Automatic Demand Control Includes:
  - Solid State Controller
  - Digital Dew Point Readout
  - High Humidity Alarm with Dry Contacts
  - Self Calibrating
  - Ambient Compensation
  - Signal Stabilizer
  - 4-20 mA Output

- All NEMA Classifications
- Pressure to 1,000 PSIG
- High Humidity Alarm
- Switch Failure Alarm
- Electronic Drain Systems
- -80 to -100°F Dew Points
- Contacts for Remote Alarms
- Oilfield Construction (See OFC Brochure)
- Flow Meter

## Capacity Correction Factors

### INLET AIR PRESSURE CORRECTION

PSI BAR	50	60	70	80	90	100	110	120	130	140	150
	3.5	4.1	4.9	5.5	6.2	6.9	7.6	8.3	9.0	9.7	10.3
FACTOR	.56	.65	.74	.83	.91	1	1.09	1.18	1.27	1.37	1.43

### EXAMPLE CALCULATIONS

#### TW500 Corrected for 120 PSI (8.3 Bar)

$$\begin{aligned} \text{CORRECTED CAPACITY} &= (\text{RATED CAPACITY}) \times (\text{PSI Correction}) \\ &= 500 \text{ SCFM (13.9 Nm}^3\text{/min)} \times (1.18) \\ &= 590 \text{ SCFM (16.7 Nm}^3\text{/min)} \end{aligned}$$



Patents issued: 6,099,620; 5,207,072; 5,099,655; 5,062,571; other patents pending. The equipment indicated in the catalog is meant for use in operating "compressed air driven" apparatuses. At no time should any Airtek equipment be used for breathing air situations unless all government regulations regarding breathing air are met.

Airtek®, Smart Cycle®, Cold Trap®, StarWatch® and PowerLoc® are Registered Trademarks of Rayco Enterprises, Inc. DBA Airtek

© 2001 Rayco Enterprises, Inc. DBA Airtek, Lancaster, New York Printed in U.S.A.  
Brochure ID # DES 1-2003

4087 Walden Avenue  
Lancaster, New York 14086  
Ph. 716.685.4040 Fx.716.685.1010

Email: [airtek@airtek.com](mailto:airtek@airtek.com)



[www.airtek.com](http://www.airtek.com)